



STI Series
Weather Stopper II

Harrington Signal Inc.
2519 4th Avenue, Moline, Illinois 61265
P.O. Box 590, Moline, Illinois 61266-0590
Phone: (800) 577-5758 Local: (309) 762-0731 Fax: (309) 762-8215
Internet: www.harringtonfire.com



FEATURES

- Serves as an inexpensive weather cover and also guards against vandalism or accidental damage, as well as helps to reduce false fire alarms.
- Cover is UV stablized against sun deterioration.
- Protects manual pull stations from dust and grime.
- When used outdoors, can pay for itself many times over (UL requires stations to be listed for outdoor use with cover).
- Guards against physical damage and vandalism.
- Available in red (blue, green and yellow as special order).
- Custom labeling available as special order.

- Unconditional lifetime guarantee against breakage of the molded polycarbonate cover in normal use.
- UL tested to NEMA 3R requirements for weather rating for moisture resistance.
- Optional mounting backplate available to help ensure proper seal on irregular mounting surfaces.
- Flush and surface mount units to fit most manual stations.

DESCRIPTION

Here is the ideal cover to help extend the life and reliability of weather exposed manual pull stations. Using the same super tough cover as the Stopper II but without the warning horn, it helps to dramatically increase the lifespan of units in saltwater areas or harsh environments. Units are molded of



STI Series

tough polycarbonate material. It also guards against physical damage and helps reduce false fire alarms. Two versions: STI-1250 for flush-mounted stations, and STI-3150 for surface-mounted units. Additional spacers may be used to accommodate even larger devices.

Ordering Information

Model Number	Part Number	Description
STI-1250	238-0107	Without warning horn for flush mount manual pull stations, includes weather gasket
STI-3150	238-0121	Without warning horn for surface mount manual pull stations (those with exposed conduit). Includes two weather gaskets and a conduit gasket.
Accessories for Above		
STI-3002	238-0147	Weather proof gasket for Stopper II units
STI-3003	238-0152	Neoprene weather proof conduit gasket (1/2" pipe)
STI-3004	238-0153	Neoprene weather proof conduit gasket (3/4" pipe)
STI-3100	238-0136	Conduit spacer, clear, 2"

STI Series Weather Stopper II

Testing Approvals

It has been tested and approved or listed by:

- Underwriter Laboratories UL No. 49G2
- New York City board of Standards No. 947-81-SA

For pull station size accomodation, refer to figures 1 & 2

Accessories

Several accessories are available for the Weather Stopper. They include a polycarbonate mounting backplate (recommended for all installations with irregular mounting surfaces), additional spacers for stations with greater depth, a heater kit to protect sensitive equipment in colder climates and a vented louver kit for areas where condensation and fogging are severe.

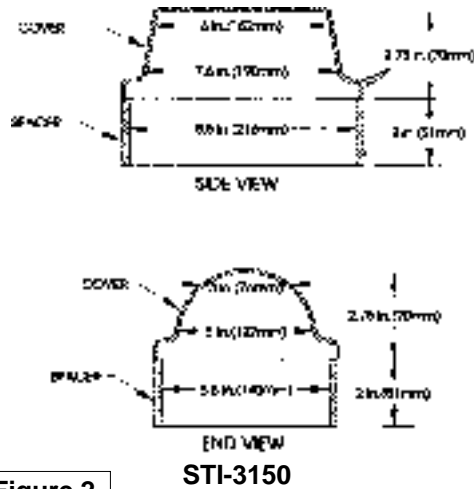

Figure 2

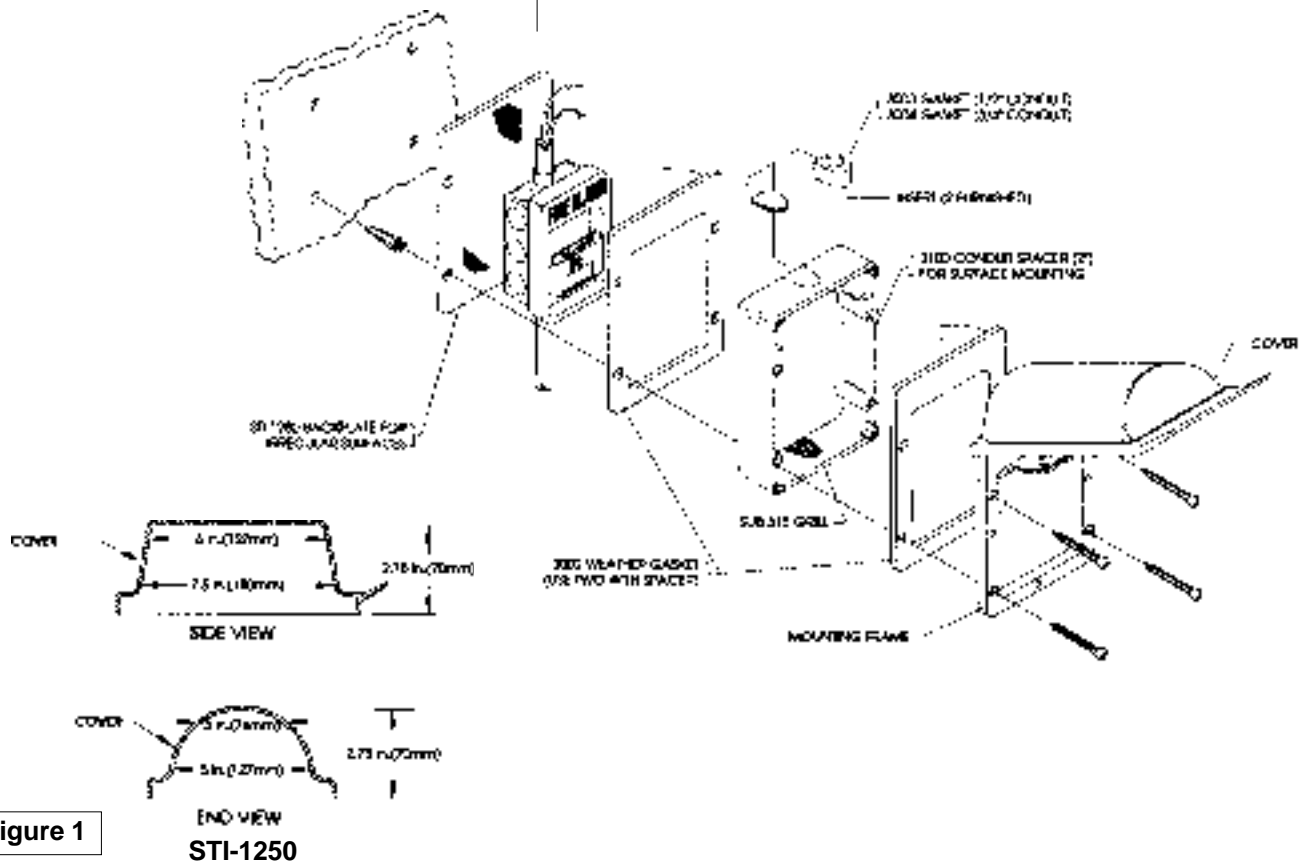

Figure 1

NOTICE: The information contained in this document is intended only as a summary and is subject to change without notice. The devices described in this document have specific instruction sheets which cover various technical, limitation and liability information. Copies of these instruction sheets and the General Product Warning and Limitations Document, which also contains important information are provided with the product and are available from Harrington Signal Inc. Fire Alarm. Information contained in these documents should be consulted before specifying or using the product. For further information or assistance concerning particular problems contact Harrington Signal Inc. Harrington Signal Inc. Fire Alarm reserves the right to change specifications without notice. Quality manufactured for Harrington Signal Inc. Fire Alarm by STI.